



LADY- 4.0 Mt



- Electromechanical barrier for passages up to 4m, intensive use
- Easy to use external manual unlock device
- Slowing down setup thanks to two adjustable limit switches
- Speed, strength and soft stop/start adjustable for an always correct use and performance
- Possibility of integrated photocells thanks to the innovative hide-away system that enables them to be perfectly integrated with the look, ensuring maximum functionality

**Equipped with
foundation plate**



Easy to use external
unlock device



Stainless steel version
available



New control panel with all
the standard features and
pull-out terminals



VE.PS

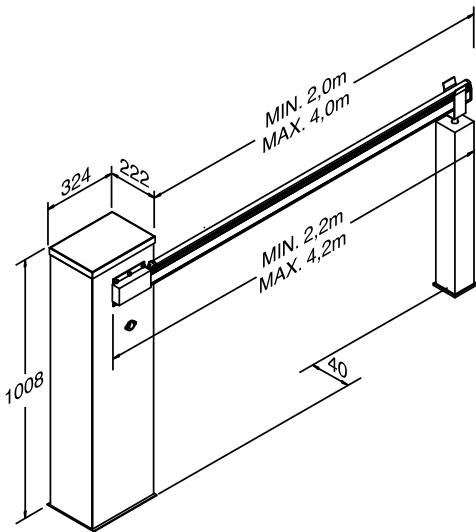
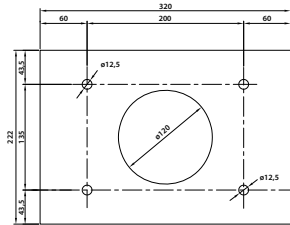

ACCESSORIES FOR USE

	2,2m	2,7m	3,2m	3,7m	4,2m
LADY.A	C	C	C	B	A
LADY.P	C	C	B	B	A
VE.RAST	C	B	B	A	-
LADY.P+VE.RAST	C	B	B	A	-
LADY.P+VE.AM	C	B	B	A	-
LADY.P+VE.RAST+VE.AM	C	B	A	-	-
SC.RES	C	B	B	A	-
LADY.P+SC.RES	C	B	A	A	-
SC.RES+VE.AM	C	B	A	A	-
LADY.P+SC.RES+VE.AM	C	B	A	-	-

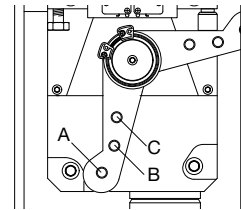

LADY.P Protection profiles.
The installation of the VE.RAST interferes with the use of the SC.RES and vice versa. The installation of the LADY.L lights kit does not influence the balancing of the bar

TECHNICAL DATA

LADY

LADY.I

Power supply	230 Vac	230 Vac
Motor supply	24 Vdc	24 Vdc
Max. Absorbed current	1,6 A	1,6 A
Torque	205 Nm	205 Nm
Opening speed	3"-5"	3"-5"
Operation cycle	intensive use	intensive use
Protection level	IP 44	IP 44
Operating Temp.	-20°C/+50°C	-20°C/+50°C
Weight	52 Kg	52 Kg
Items no. per pallet	9	9

QUALITY AUTOMATIONS

Add : #351 &352, Kempegowda Layout, Outer Ring Road, Laggere, Bangalore - 560058. INDIA _ Tel. +91 080 28397671 / + 91 9591975597 / +91 9686077009

Email - info@qualityautomations.com , Website : www.qualityautomations.com